

Present and Future Airborne and Space-borne Systems

Wolfgang Keydel

Microwaves and Radar Institute

German Aerospace Research Centre (DLR), Oberpfaffenhofen

Contact Address:

Mittelfeld 4

D-82229 Hechendorf

Germany

E-mail: wolfgang.keydel@dlr.de

Abstract

The state of the art of both airborne and space-borne SAR systems with polarimetric interferometry capability, their technological, system technical and application related specifications, and recent results obtained as well are presented shortly with respect to their relevance for Polarimetry and Interferometry capabilities. Space-borne SAR interferometry in two pass mode reaches altitude accuracies of about 10 m and in one pass mode of < 6 m. With differential interferometry accuracies in the cm range have been obtained. In order to reach these values an exact system calibration is indispensable. The calibration of space-borne systems will be discussed using SRTM as an example. The future development of space-borne systems will be discussed shortly also.

1. Introduction

SeaSAT A, launched in June 16, 1978, was the first satellite designed for operational sensing of the Earth's oceans with SAR. Specific objectives were to collect data on sea-surface winds, ocean topography, sea-surface temperatures, wave heights, wave length and direction, atmospheric water, and sea ice features in L-Band. The mission ended after 116 days due to a failure of the vehicle's electric power. Up to now SeaSAT had a large fleet of both military and civil successors steadily improved with respect. A representative collection of 20 of these Instruments is collected exemplarily by Kramer, 2000, together with a representative collection of airborne SAR which have been developed worldwide within the same time frame. Recently UAV's gain increasing attention for both military and civil applications also.

Exemplary for the state of the art of space borne SAR techniques and their application are the two Space Shuttle SAR SIR-C/X-SAR flown twice in February and October 1994 and the SRTM/X-SAR flown in February 2000 respectively. These were up to now the most modern realized space-borne SAR systems. The actual satellites ENVISAT, the youngest member of the European ERS-Family, and the Canadian RadarSAT as well are representative also for the today's possibilities. Space-borne SAR systems which are presently under development are the two German Projects TerraSAR-X and SARLupe, the launches are foreseen for 2006, and the Canadian RadarSAT 2 to be launched probably at the End of 2004.

2. X-SAR/SIR-C and X-SAR/ SRTM

Both SIR-C/X-SAR and X-SAR/SARTM were cooperative projects between NASA/JPL (Jet Propulsion Laboratory), DARA (German Space Agency), DLR (German Aerospace Research Centre) and ASI (Italian Space Agency). Both Missions and their results are most exemplary for space-borne Polarimetric and Interferometric SAR. Therefore, a more extended attention will be paid to these two systems beside any other Satellite missions which have been performed in the past or which are in orbit presently.

2.1 X-SAR/SIR-C

On the experimental SIR-C/X-SAR missions, three SAR instruments operating in L-, C- and X-band (corresponding to wavelengths of 24 cm, 6 cm and 3 cm respectively) are flown twice in 1994 (April 9th to 20th and September 30th to October 10th) on the Space Shuttle. The L- and C-Band sensors (the US contributions) were full polarimetric whereas the X-Band sensor (the German/Italian contribution) had single polarization (VV).

During these two missions more than 230 test sites were imaged worldwide covering two periods of the vegetation growing season.

Paper presented at the RTO SET Lecture Series on "Radar Polarimetry and Interferometry", held in Brussels, Belgium, 14-15 October 2004; Washington, DC, USA, 18-19 October 2004; Ottawa, Canada, 21-22 October 2004, and published in RTO-EN-SET-081.

	L-band	C-band	X-band
Radar wavelength	0.2423 m	0.0567 m	0.0312 m
Polarization	VV, HH, VH, HV	VV, HH, VH, HV	VV
Pulse repetition frequency	1736 Hz	1736 Hz	1736 Hz
Range sampling rate	44.9971 MHz	44.9971 MHz	22.4985 MHz
Platform velocity [7255 m/sec	7255 m/sec	7255 m/sec
Look angle	≈ 49°	≈ 49°	≈ 49°
Squint angle (pass 1/pass 2)]	-0,16° / -0,25°	-0,16° / -0,25°	-0,16° / -0,25°
Azimuth SAR image resolution	5.8 m	5.8 m	6.15 m
Slant range SAR image resolution	3,7 m	3,7 m	6.9 m
Interferogram azimuth resolution	54 m	54 m	30 m
Interferogram slant range resolution	17 m	17 m	20 m
Interferogram ground range resolution	≈ 22 m	≈ 22 m	≈ 28 m

Tab 1 X-SAR and SIR-C Specifications

For the first time in the history of space based radar it was possible with SIR-C/X-SAR to monitor a wide variety of sites around the globe, imaging them simultaneously in different wavelengths and polarisations with the same local weather conditions, the same radar parameters and perfect co-registration of the images. The ability to point the radar antenna at different angles enabled sites to be imaged under various incidence angles and polarizations as well. Reflective properties of certain targets could be measured with SIR-C/X-SAR in both a two day interval and a five month interval, providing short term and long term, i.e half-yearly, observations of changing phenomena.

Never before and never after up to now has there been such an ambitious earth observation experiment, where compatible remote sensing data could be gathered from space with a wide range of imaging parameters, even permitting multi temporal, multi frequency and multi polarization investigations. The SIR-C/X-SAR missions are, therefore, major milestones for space based radar, giving us a glimpse of the satellite remote sensing systems of the future also.

2.2 X-SAR/ SRTM

X-SAR/SRTM was Germany's and Italy's contribution to the operational Shuttle Radar Topography Mission (SRTM), which has been operated from February 12th 2000 to February 21st 2000 on the Spac Shuttle Endeavour (STS 99). It was a X-Band radar interferometer which operated in union with the C-Band interferometer of the US in an operational mapping mission. The Mission Objectives which have been obtained completely were to use C-band and X-band interferometric SAR to acquire data over 80% of Earth's land mass (between 60°N and 56°S) and to produce topographic products which meet Interferometric Terrain Height Data (ITHD) specifications: The C-Band Radar-Interferometer, an US-Instrument, and the X-Band Radar-Interferometer X-SAR was Germany's and Italy's contribution. Both Instruments have been used for the X-SAR/SIR-C mission with minor changes only. However in order to perform single pass interferometry to each radar a second receive channel mounted on the tip of a 60 m long boom was added. The 12 meter long and 40 centimetre wide X-SAR main antenna for transmit and receive (channel one) was mounted directly to a tiltable part of the 12 meter C-radar antenna truss structure in the shuttle's cargo bay. The second (receive-only) X-SAR antenna was 6 meter long and was, together with the second 8 meter long C-band antenna, mounted onto the tip of a 60 meter long, deployable, stiff, boom structure perpendicular to the velocity direction of the space shuttle, to build the baseline. Due to mechanical constraints, the interferometric baseline did not only consist of the terrain height sensitive across track component but also

contained an along track component of 7 m. The resulting time lag between the data acquisitions by the two antennas causes phase differences, which are proportional to the line of sight velocity of moving targets. That configuration, the space shuttle with its 60-meter mast extended from the cargo bay was the longest structure ever flown in space it is depicted in Fig.2.1 schematically.

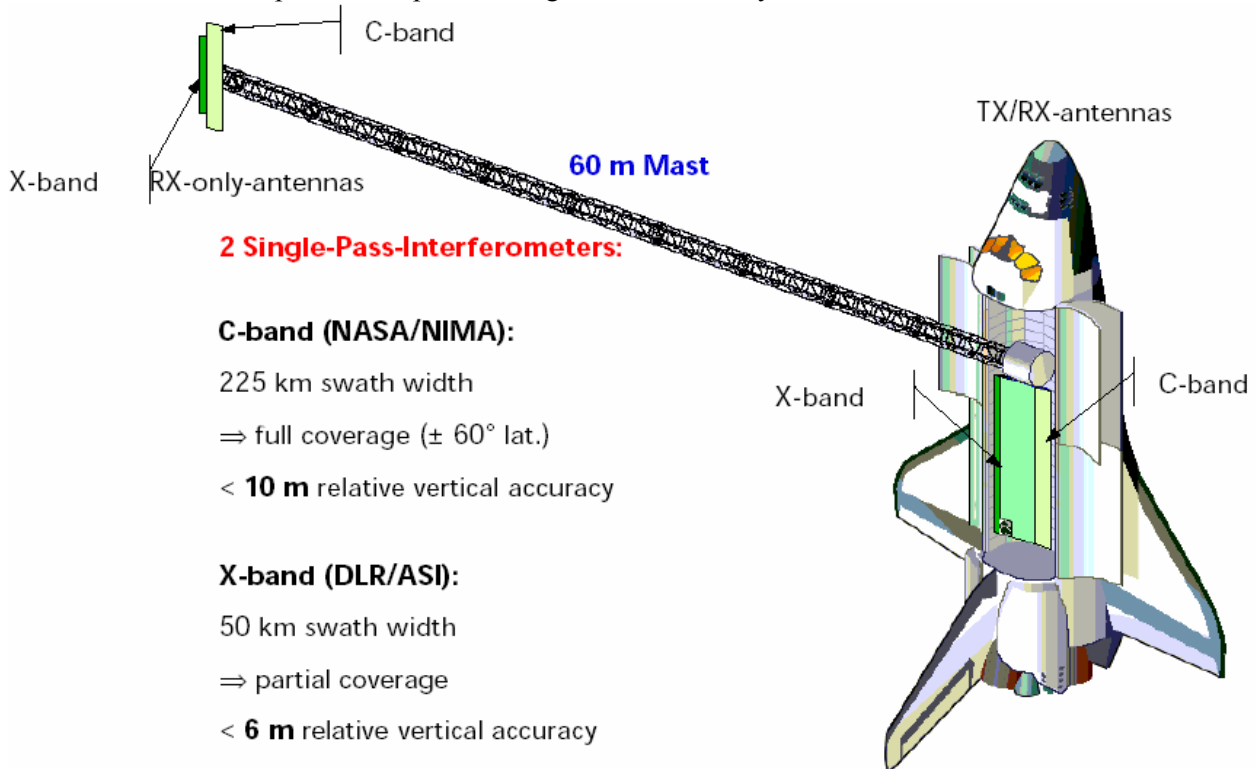

Fig.2.1 Schematic representation of the SRTM flight configuration

X-SAR was not capable of operating in a ScanSAR mode like the C-radar which would allow complete coverage of the Earth during the short orbiting period of 11 days or 166 orbits. X-SAR operated, in turn, in a higher-resolution mode with a smaller swath width of approximately 50 km placed inside the 250km SIR-C scan swath at an angle of 54.5 degrees off-nadir.

The C-band and X-band could operate simultaneously or independently. For the most part, they operated together. The advantage was the ability to crosscheck the maps produced by the two systems. The primary X-Band antenna could be tilted in elevation mechanically to align its beam with the one of the secondary antenna. To accomplish an azimuth in-orbit alignment of both antennas an electronic beam steering of both receive antennas within a range of 0,9 degrees in steps of 0.3 degrees has been installed. However, it was not necessary to use this equipment during the mission. The two-channel output data streams, with 90 Mbit/sec, were multiplexed for recording on cassette tape recorders onboard or down linked at half the rate. These represent the raw amplitude and phase data for the two images to be processed to create the interferometric fringes on ground after the mission. For X-SAR alone more than 80 hours of data takes have been recorded on 110 cassette tapes. Table 2 shows a comparison of the four channels used. For the exact determination of the important attitude and orbit data of the shuttle the Attitude Orbit Determination Avionics (AODA)-system on board of the shuttle was responsible, which was mounted on the antenna structure directly. This and the Calibration Procedures will be described in the next chapter 3.

The heights above ground derived for both instruments were compared with sea level height measured independently with satellite radar altimetry (ERS and TOPEX POSEIDON) to better than 10 cm for non coastal waters. Using these results the Attitude Orbit Determination Avionics (AODA)-system has been calibrated. By optimizing the instrument alignment parameters as well as the processing algorithms, which digest the AODA raw data, errors on scales of 1000 km and less have been reduced by over an order of magnitude since the begin of the calibration phase; remaining errors are on the order of +/-10 m rms (Rosen 2001).

The final products of the SRTM mission [DLR/DFD Homepage, Eineder et.al. 2000, Werner 2000] are

	X-Band Primary	X-Band Secondary	C-Band Primary	C-Band Secondary
Frequency	9.6 GHz	9.6 GHz	5.3 GHz	5.3 GHz
Polarization	VV	V	H, V	H, V
Polarization Isolation	39 dB		>25 dB	>25 dB
Adjustable Off-Nadir Angle	15° - 55° mechanical	54° -55° mechanical	15° - 55° electronic	15° - 55° electronic
Off Nadir during Mission	54.5°	55.5°	36.5°, 46.5°, 53°, 58°	36.5°, 46.5°, 53°, 58°
Adjustable Horizontal Angle	0°	0.9° step 0.3°		
Swath Width	45 km	45 km	225 km	225 km
Azimuth Res. (4 looks)	25 m	25m	30m	30m
Range Resolution				
10 MHz/20 MHz Bandwidth	20 m / 10 m	20 m / 10 m	25 m / 13 m	25 m / 13 m
Total Dynamic Range	60 dB	60 dB	60 dB	60 dB
Radiated Peak Power	3.5 kW		1.7 kW	
Main Antenna Area	0.4 m x 12 m	0.4m x 6m	0.7 m x 12	0.7m x 8m
Main Antenna Gain	43.5 dB	41,8 dB	42.8 dB	40,0 dB
Elevation Side Lobe	-20 dB	-21 dB	-18 dB	-19 dB
3 dB Beam Elevat. /Azimuth	5.5° / 0.14°	5,3°/0,28°	4.9° / 0.25°	4,9°/37,5°
Radiometric Resolution	2.5 dB	2.5 dB	1.5 dB	1.5 dB
Data Rate / Channel	45 Mb /sec	45 Mb /sec	45 Mb/sec	45 Mb/sec

Tab.1 X-SAR/SIR-C Key Specifications

digital elevation products in a mosaic format generated from C- and X-band radar frequencies. X-band full coverage begins at latitudes greater than about 55° North/South. The C-band radar has completely covered the land surface between 60° North and 58° South with multiple overlap in the higher latitudes. The complex SRTM data required two years to convert the raw radar data into topographic maps. Resulting data formats are compatible with standard cartographic data-analysis software and tailored to the needs of the scientific, commercial and operational user communities. More detailed specifications of the X- Band are delineated below.

- 6 m <vertical relative accuracy < 10 m (90% linear error)
- 15 m < horizontal relative accuracy < 15 m (90% circular error)
- 16 m < vertical absolute accuracy < 16 m (90% linear error)
- 20 m <horizontal absolute accuracy < 20 m (90% circular error)

Apart from digital terrain height maps in two different resolutions, there are multi-look images in ground range, single look images in slant range as well as terrain-corrected data and incidence angle masks. The measurement of topography in vegetated regions through SAR techniques caused in some areas deviations from the true terrain height because the short radar wavelengths of C- and X-band (5.3cm and 3.1cm, respectively) sensed primarily the very top of dense canopies or high buildings.

Fig. 2.2 shows the very first result obtained 11 hours after launch the interferometry fringes as well as the resulting (DEM) of an area around White Sands in New Mexico, United States. The DEM is color coded AODA raw data, errors on scales of 1000 km and less have been reduced by over an order of magnitude since the begin of the calibration phase; remaining errors are on the order of +/-10 m rms (Rosen 2001). Products, [DLR/DFD Homepage, Eineder et. al. 2000, Werner 2000]

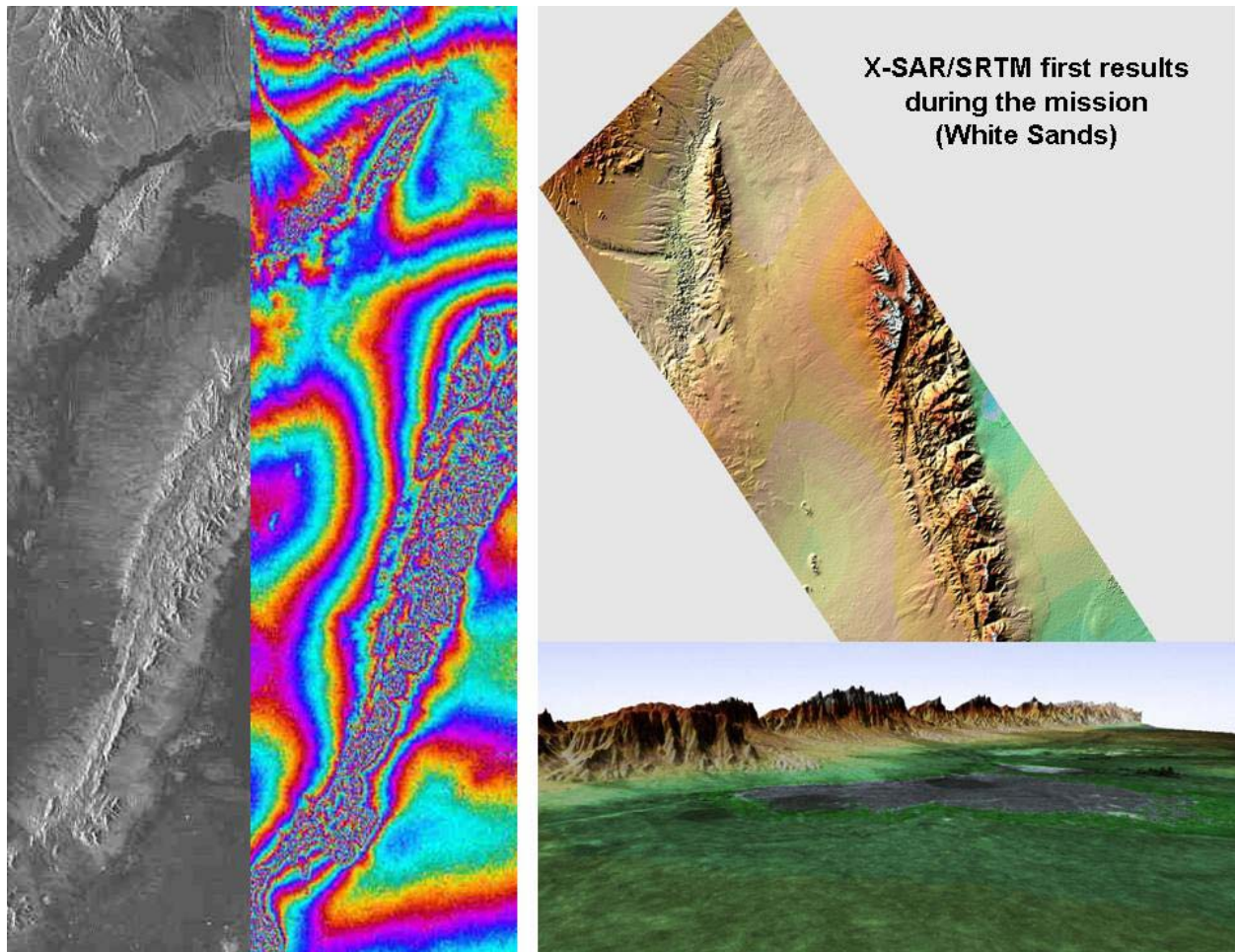

Fig. 2.2 First SRTM-Result, X-Band SAR image, fringes, color coded map, and 3-D representation of an area around White Sands, New Mexico, USA.

REFERENCES

DLR/DFD Homepage <http://www.dfd.dlr.de/srtm/>

Eineder, M., R. Bamler, N. Adam, H. Breit, S. Suchandt, U. Steinbrecher: SRTM/X-SAR Interferometric Processing-First Results, EUSAR 2000, 3rd European Conference on Synthetic Aperture Radar, 23 – 25 Mai 2000, Munich, Germany, pp 233 -236

Farr T, M. Kobrick, "The Shuttle Radar Topography Mission: A Global DEM, ", IGARSS Proceedings 2000. JPL Homepage: <http://www.jpl.nasa.gov/srtm/>

Werner, M. Shuttle Radar Topography Mission (SRTM)-Mission Overview, Proc. EUSAR 2000, 3rd European Conference on Synthetic Aperture Radar, 23 – 25 Mai 2000, Munich, Germany, pp.209 - 212

Werner, M., Kay-Bodo Klein, Martin Haeusler. Performance of the Shuttle Radar Topography Mission, X-Band Radar System

Werner, M., Operating the X-band SAR Interferometer of the SRTM

Zink, M., D. Geudtner: First Results from The Calibration of the Interferometric X-SAR System on SRTM, EUSAR 2000, 3rd European Conference on Synthetic Aperture Radar, 23 – 25 Mai 2000, p 223

3. Systems Calibration

The calibration relates the SAR image intensity to radar backscattering coefficients and provides information about the accuracy of this relationship. Estimation and removal of all system-related influences results in pure object signatures. The goal is to model the relationship between geophysical parameters and measured backscattering coefficients. Such quantitative analyses and the development and interpretation of models in different geophysical applications require calibrated data.

An overall system calibration includes:

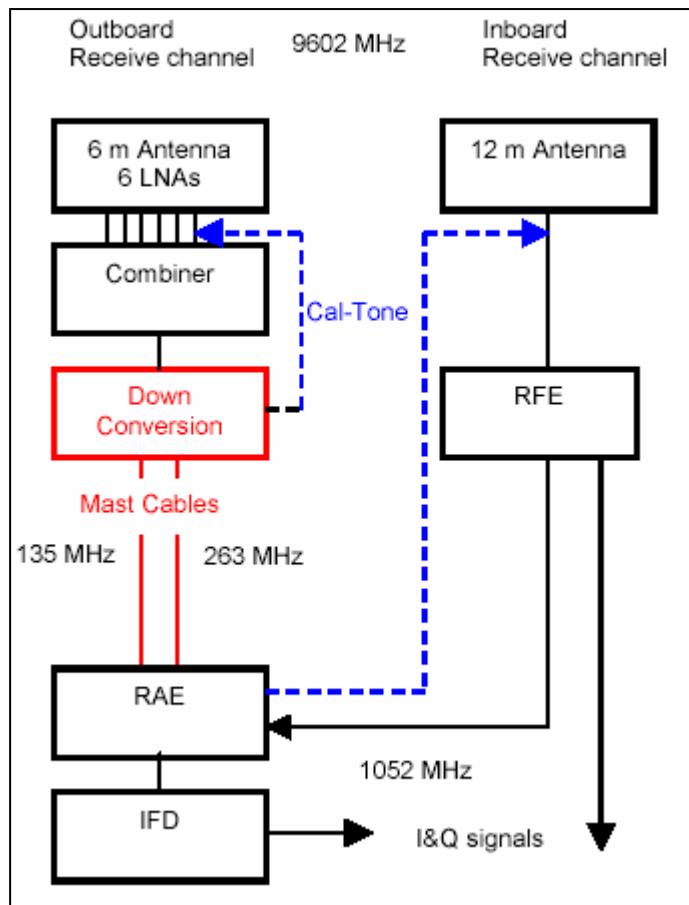

Fig.3.2 Blockdiagramme of the X-SAR receive channel with path of calibration tone(Werner 2001)

- Internal calibration: Compensation and correction for system errors in amplitude and phase
- Exact Attitude and Orbit control of the Platform
- External calibration

The calibration of the SRTM systems is exemplary for an overall calibration procedure

Besides the phase errors caused by the shuttle and mast dynamic variations and the position and attitude inaccuracy, there are phase errors originating from the radar instrument itself that may be compensated. Temperature variations and radar parameter changes like gain settings are the major contributors to these phase errors. During the whole 10 day mission recorded telemetry data indicating periodic temperature variation along with the orbit were monitored. Temperature variations in microwave devices and cables cause a phase variation, which contributes to the overall phase error and degrades the accuracy of the interferometric height measurement. The phase errors have been measured directly, like for the long mast cables, or derived from the calibration tone phase analysis or simply by correcting the known phase to temperature characterization values of the microwave parts with the measured mission temperature data.

3.1 The Instrument Phase Error determination of X-SAR

The main task of internal calibration is the determination of deterministic instrument phase errors as far as possible. This principally, is necessary always before starting the operational processing of all the acquired interferometric SAR data.

Microwave components like wave-guides, coax cables, amplifiers, phase shifters and mixers alter the phase of the signal depending on the temperature, mainly due to the change of the electrical length of the signal path. The high temperature variations between -25°C and +20°C were the major error source within the instrument. Depending on the orbit position with its different sun and shadow conditions, the measured phase variation was up to 7° within one orbit. An uncompensated mast phase error would result in height errors of more than 27 meters over a 20 minute or 1500 km long data take.

Therefore, a careful characterization of all phase sensitive devices and the monitoring of their temperatures during the mission as well as the availability of a stable and reliable calibration signal was necessary to remove and compensate for systematic phase errors caused by the instrument. For this purpose a calibration-tone has been injected as a well-defined and stable signal into both channels. The phase difference between the cal-tones in the primary and secondary channel provided a monitoring of the variations in instrument phase difference. Without the instrument calibration the additional height error of up to 50 meters would have superseded our specification of 6 meters (relative), 10 meters (absolute) by far. This points out the tremendous importance of the calibration for Interferometric SAR systems

3.2 Motion Compensation: The Attitude Orbit Determination Avionics (AODA)

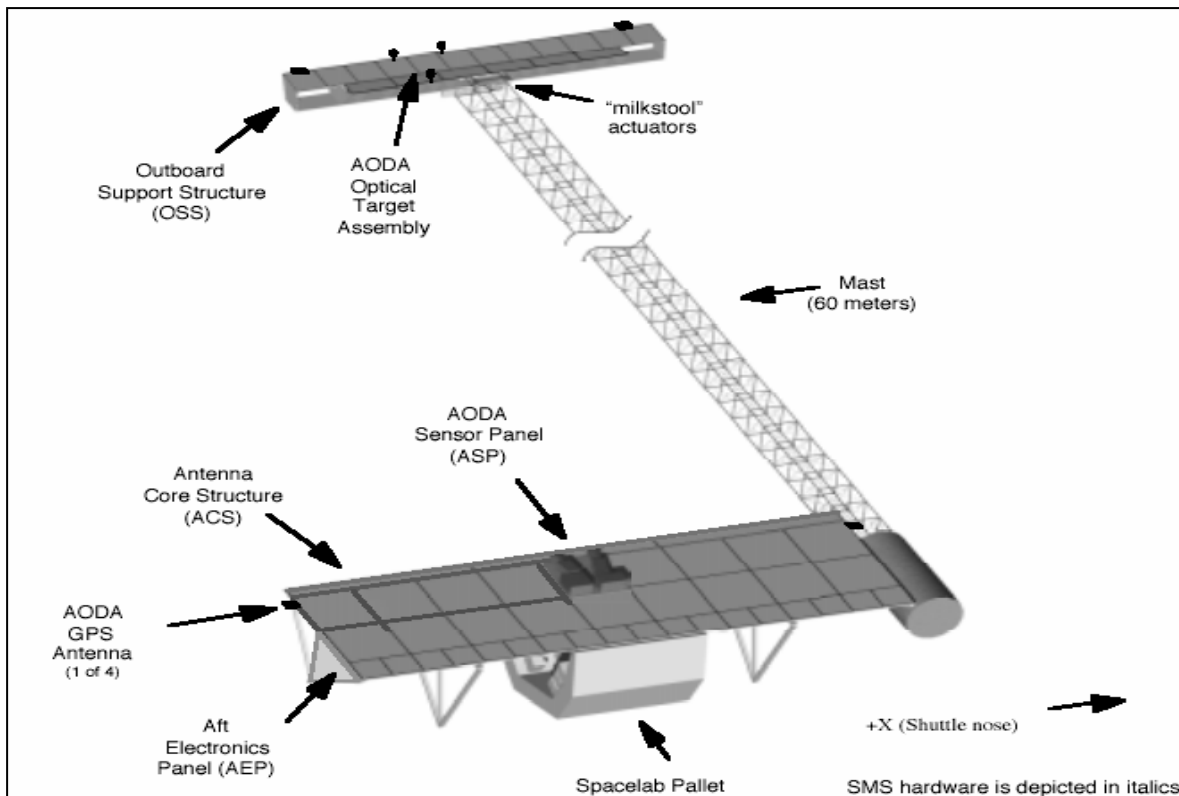

Fig. 3.3: The Attitude and Orbit Determination Avionics (AODA) flight configuration

The sensor motion in the line of sight is mainly caused by the mast oscillation which causes an azimuth shift of the SAR impulse response function and affects the resolution if the velocity is high. It increases the interferometric phase noise, leads to a mis-registration and intolerable Phase errors and, therefore, must be compensated. [Just D., R. Bamler 1994]. The AODA system supplies extremely accurate observation geometry data. The motion compensation is therefore able to adjust the motion effects in the secondary scene and reaches the required accuracy. This technique contributed to the most complete, accurate and homogeneous DEM of the world. A sensor trajectory which considerably reduces the motion of the sensor in the line of sight is calculated e.g. by smoothing the reference track. The phase corresponding to the distance in the line of sight between the original and the calculated trajectory has to be added to the single SAR scenes depending on range and azimuth. Therefore, the sensor position for each image sample has exactly to be known. Within this system, the baseline is measured to 2 mm, the shuttle attitude to 9 arcsec and the shuttle position to 1 m as 1.6 sigma level accuracy [Duren et.al 1998].

The Attitude and Orbit Determination Avionics (AODA), depicted in Fig.3.3 was developed by the NASA to provide the necessary baseline metrology. State-of-the-art of satellite tracking techniques, principally, include the following instruments which were available at the AODA System. A suite of sensors was responsible for measuring and controlling the proper alignment of the secondary antenna with respect to the main antenna and the attitude and position of the interferometric system in orbit.

GPS allows the determination of the satellite's position and velocity.

- Radar Altimetry measures the satellite's altitude above the surface.
- Laser Ranging estimates the satellite's distance to selected reference stations using laser systems.
- Microwave Ranging estimates the satellite's distance to selected reference stations using microwaves with a Precision Range and Range Rate Equipment (PRARE) for exact attitude determination
- Inertial Reference (Unit IRU) measures the relative change of the platform's attitude onboard, using e.g. gyro systems.
- Star Tracker are used to determine the platform's orientation with respect to inertial space

The star tracker has measured the orientation of the interferometric system in orbit, which is supported by an inertial reference unit consisting of three 2-axis gyros. An optical tracker of the secondary antenna which is a video camera and LED targets, will allow a relative 3-axis measurement of the boom antennas. Additionally, GPS antennas on the secondary antenna structure will provide a 0.8m orbital position accuracy determination and, furthermore, a time reference for the radar with an accuracy of 100 μ sec.

3.3 External Calibration

The task of the on-ground calibration was to set up precisely surveyed control targets for both the radiometric and interferometric calibration, 22 calibration fields distributed all over the world have been established.

Hence, in the area from Bayreuth down to Füssen in Bavaria, Germany, a calibration field was set up encompassing 27 different locations, in which passive as well as active reference targets (trihedral corner reflectors and transponder respectively) and calibrated ground receivers were erected. The field encompassed an area of about 300 km x 100 km roughly in SSW to NNE direction. By using the ground receivers and the transponders, the antenna patterns of both the German-Italian X-SAR-System and the American SIR-C-Radar could be measured, which is required for radiometric calibration. The corner reflectors served as reference points in the topographic data to calibrate the phase. Some corner reflectors had to be moved between passes. All had to be pointed towards the shuttle before a pass. Furthermore, it was necessary to determine the geographical location of every corner site very precisely by using differential GPS.

The interferometric calibration concept for X-SAR considered beside the instrument phase calibration the InSAR (Interferometric SAR) imaging geometry calibration also. A height error may result from errors due to uncertainties in the imaging geometry parameters, such as baseline length and tilt angle, and orbit data, and from phase variations caused by the instrument

The ocean surface served as reference height. Before and after each continental pass, there was a calibration over the ocean (Fig. 3.4). The phase calibration had to be performed for time and temperature variations. Pre-flight characterization of the behaviour of critical parts was required for estimating the residual calibration error. In certain cases these parameters in combination with temperature measurements can be sufficient for later correction.

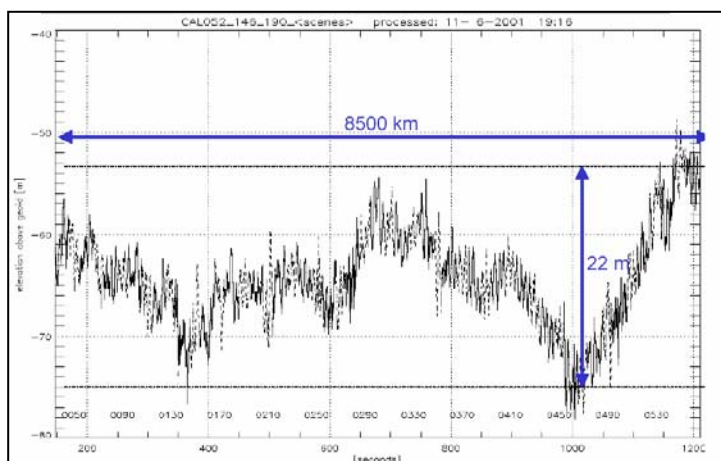

Fig.3,4 Result of altitude measurements over the Ocean during 480 sec

REFERENCES

Adam, N, M.Eineder; H. Breit; SRTM X-SAR Motion Compensation: Concept and first Assessment of the Interferometric Observation Geometry. Proc. IGARSS 2001,Session SS09WE, Sydney, Australia

R. Bamler, "A world-wide 30 m resolution DEM from SAR interferometry in 11 days," *47th Photogrammetric Week*, 1999.

Bamler R., H. Breit, M. Eineder, "The X-SAR single-pass interferometer on SRTM: Expected performance and processing concept," *EUSAR '96*, pp. 181-184, 1996.

Eineder M.ed all ."SRTM X-SAR Calibration results". Proc. IGARSS 2001,Session SS09WE, Sydney, Australia.

Duren R.; Shuttle-Radar-Topography-Mission, Attitude and Orbit Determination Avionics (AODA), Functional Requirements Document, rev. A Jet Propulsion Laboratory, JPL D-14403, August 26 1997

Duren, R. "Attitude and orbit determination avionics (AODA) functional requirements document," *JPL D-14403*, vol. rev C, 1999.

Duren R., E. Wong, B. Breckenridge, S. Shaffer, C. Duncan, E. Tubbs, P. Salomon, "Metrology, attitude, and orbit determination for spaceborn interferometric synthetic aperture radar," SPIE AeroSense Conference on Acquisition, Tracking and Pointing XII, 1998.

T. Farr, "The shuttle radar topography mission," *IGARSS 2001*, 2001.

Francheschetti G., A. Iodice, S. Maddaluno, D. Ricco, "Effects of secondary antenna oscillations on X SAR/SRTM performance," *IGARSS 1999*, 1999.

Just D., R. Bamler, "Phase statistics of interferograms with applications to synthetic aperture radar," *Applied Optics*, vol. 33, no. 20, pp. 4361–4368, 1994.

Keydel, W., Hounam D., Pac R., Werner M. (2000): X-SAR/SRTM - Part of a global Earth Mapping Mission. RTO Meeting Proceedings 61, Space-Based Observation Technology, RTO MP-61, ISBN 92-837-1050-9, October 2000, p. 32 ff

Stevens D.R., I.G. Cumming, A.L Gray, "Options for airborne interferometric SAR motion compensation," *IEEE Trans. Geosci. Remote Sensing*, vol. 33, no. 2, pp. 409–420, 1995.

Werner, M. "Operating the X-band interferometer of the SRTM," *IGARSS 2000*, 2000.

Werner, M, M. Häusler, X-SAR/SRTM Instrumrnt Phase Error Calibration, Proc. IGARSS 2001, Session SS09WE, Sydney, Australia

Zink M. and D. Geudtner, "Shuttle Radar Topography Mission: X-SAR Calibration and Validation Concept," Proc. EUSAR '98, Friedrichshafen, Germany, pp. 195-198, 25.-27. May 1998.

4. The European ERS Family from ERS-1 to ENVISAT /ASAR

Since 1991 until now the ERS satellites were the European working horses of the worldwide Remote sensing Community. ESA has launched the ERS-1 in July 1991 and the ERS-2, which is still in orbit, in April 1995. Just recently, in 2002, the last "update" of this Family, the ENVISAT with the Advanced SAR Instrument ASAR has been launched. Basic SAR Instrument characteristics of ERS-1/2 are listed in Table. 4.1

Frequency	5.3 GHz	Antenna size	10 m x 1 m
Polarisation	Linear VV	Incidence angle	23° nominal
Bandwidth	15.55 MHz	Swath width	100 km
Peak power	4.8 kW	Resolution Az x Rge	30m x 26.3 m
Tab. 4.1 Basic ERS-1 SAR Characteristics			

The Advanced Synthetic Aperture Radar (ASAR) was built upon the experience gained with the ERS-1/2 Active Microwave Instrument (AMI) to continue and extend Earth observation with SAR. ASAR is a high-resolution, wide-swath imaging radar instrument that can be used for site-specific investigations as well as land, sea, ice, and ocean monitoring and surveillance. Compared to ERS AMI, which is a single-channel, fixed-geometry instrument, the ASAR instrument provides a number of technological improvements. Significant advances have been made in both system flexibility and the scientific value of its data sets, employing a number of new technological developments that allow extended performance. The most challenging advancement has been the replacement of the centralized high-power amplifier, combined with the wave guide slot passive radiator array of the AMI, by an active phased-array antenna system using distributed elements. Transmit/Receive (T/R) modules are arranged across the antenna such that, by adjusting the gain and phase of individual modules, the transmit and receive beams may be steered and shaped, allowing the selection of different swaths and providing a swath coverage of over 400-km wide using ScanSAR techniques. The main improvements of ENVISAT/ASAR against The ERS SAR are

- Instrument enhancements that include a digital chirp generator (programmable from 200 kHz to 16 MHz) and an improved linear dynamic range.
- Flexible swath positioning; offering the choice between several image swath positions at various distances from the sub satellite track, with different incidence angles.

- Dual polarisation; offering horizontal (HH) & vertical (VV) or cross polarisation (HH&HV or VV&VH) operation
- Wide swath coverage; 405 km swath with 150 m or 1 km resolution
- Global SAR coverage is possible using the solid state recorder or data relay satellite

ASAR provides continuity of the ERS SAR Image and Wave Modes, but with the opportunity for better temporal frequency of coverage. The nominal 30 m spatial resolution and swath coverage of the ASAR Image Mode (100 km) and Wave Mode (5 km) are the same as the ERS Image Mode, and ASAR will also be on a 35 day repeat orbit also. Table 4.1 shows the nominal ASAR characteristics represented by the different Modes. An Improvement can be obtained with combinations of two of these interferometric modes respectively, namely: IM/IM, AP/AP, AP/IM, WSM/IM together with a Digital Elevation Mode. This will allow Multimode Interferometry.

Image Mode (IM)	VV or HH polarisation images from any of 7 selectable swaths. Swath width between approximately 56 km (swath 7) and 100 km (swath 1) across-track. Spatial resolution of approximately 30 m (for precision product).
Alternating Polarisation Mode (AP)	Two co-registered images per acquisition, from any of 7 selectable swaths. HH/VV, HH/HV, or VV/VH polarisation pairs possible. Spatial resolution of approximately 30 m (for precision product).
Wide Swath Mode (WS)	400 km by 400 km wide swath image. Spatial resolution of approximately 150 m by 150 m for nominal product. VV or HH polarisation.
Global Monitoring Mode (GM)	Spatial resolution of approximately 1000 m in azimuth by 1000 m in range for nominal product. Up to a full orbit of coverage. HH or VV polarisation.
Wave Mode (WV)	A small imagette (dimensions range between 10 km by 5 km to 5km by 5km) is acquired at regular intervals of 100 km along-track. The imagette can be positioned anywhere in an Image Mode swath. Up to two positions in a single swath or in different swaths may be specified, with acquisitions alternating between one and the other (successive imagettes will hence have a separation of 200 km between acquisitions at a given position). HH or VV polarisation may be chosen. Imagettes are converted to wave spectra for ocean monitoring.

Table 42 Nominal ASAR characteristics

With the Image Mode the ASAR generates high spatial resolution products (30 m) similar to the ERS SAR. It will image one of the seven swaths located over a range of incidence angles spanning from 15 to 45 degrees in HH or VV polarisation.

- The Alternating Polarisation Mode provides high-resolution products in any swath, as in Image Mode, but with polarisation changing from sub-aperture to sub-aperture within the synthetic aperture. Effectively, a ScanSAR technique is used but without varying the sub-swath. The results are in two images of the same scene in different polarisation combinations (HH/VV or HH/HV or VV/VH) with approximately 30 m resolution (except IS1). Radiometric resolution is reduced compared to Image Mode.
- In the Wide Swath Mode the ScanSAR technique is used, providing images of a wider strip (405 km) with medium-resolution (150 m) in HH or VV polarisation. The total swath consists of five sub-swaths and the ASAR transmits bursts of pulses to each of the sub-swaths in turn in such a way that a continuous along-track image is built up for each sub-swath.

The Alternating Polarization mode of ASAR is capable to provide multi-polarimetric images by means of ScanSAR acquisitions, where switching is made on polarizations instead than sub-swaths. The purpose of AP interferometry is to estimate the Polarimetric Phase Difference and the polarimetric correlation. This information is of great help in the processes of identification and classification of different types of scattering mechanisms areas, and where the penetration depth is different at different polarizations.

The ASAR sensor is capable of simultaneously acquire two different ScanSAR images on the same swath: either HH/VV, or HH/HV, or VV/VH. Two of these images respectively have different spectral contributes

and could not be combined together, but rather with another AP mode or an IM mode acquisition (either in HH or in VV mode), of the same area. The IM data is split in two parts, each of them coherent with either the HH or the VV AP polarization, through an azimuth space varying filtering. An interferogram is then formed for each of the two coherent AP-IM combinations; a differential interferogram is finally generated after an adaptive filtering process that improves the SNR of the two AP IM interferograms (Pasquali, et. al, 1998). This technique has been used for the SIR-C SCANSAR-Mode. Table 4.3 summarizes the most important ASAR Performance features.

Parameter	Image Mode	Alternating Polarization Mode	Wide Swath Mode	Global Monitoring Mode
Polarization	VV or HH	VV,HH,HH/HV or VV/VV	VV or HH	VV or HH
Spatial Resolution (Az x Rg)	27,5m x 28,1m	29m x 30m	145m 145m	27,5 m x 29,6 m
Radimetric Resolution/dB	1,54	2,50	1,45 x 1,72	1,54
Point Target Ambiguity				
-Azimuth/dB	25,9 – 29,6	19,1 – 28,0	22,3 -28,6	27,3 - 29,6
-Range/dB	31,6 -45,9	26,4 – 40,5	25,0 -33,9	31,2 - 45,7
Distributed Target Ambiguity				
-Azimuth/dB	22,6 - 24,7	18,1 – 24,5		22,6 - 24,7
-Range	17, 1 – 39,4	17,1 39,4		21,2 - 47,7
Radiometric Stability/dB	0,32 – 0,40	05 – 0,55	0,32 -0,42	0,55 - 0,60
Radiometric Accuracy/dB	1,17 – 1,38	1,62 – 1,81	1,20 – 1,45	1,80 - 1,94
Noise Equivalent σ_0/dB	19,6 – 22,1	-19,4 -21,9	-20,9 –26,2	31,5 – 35,0

Table 4.2 ASAR Performance Summary for the different Modes(Torres et. Al. 1998)

4.1 Tandem Missions

The SAR of ERS-2 is practically identical to that of ERS-1. The orbits of ERS-1 and 2 were such that ERS-2 followed the same ground track as ERS-1, except for a 1-day delay. This provided an opportunity to obtain tandem interferometric data of an area using the SAR on the two satellites. The tandem data had better coherence property than the data obtained from 35-day repeat passes of a single satellite. The tandem mission was operational from April 1994 to June, 1996 after the launch of ERS-2. ERS-1 had outlived its planned operational life and was deactivated after the tandem mission.

Currently, ERS-2 still remains in active operation and the possibility of ERS and ENVISAT cross-interferometry has been demonstrated also (Arnault, 2003). However, the interferometric combination of ENVISAT and ERS data is not as simple as it used to be with the similar constructed SAR sensors on board the ERS-1 and ERS-2 satellites. The radar centre frequency of ENVISAT/ASAR (5.331 GHz) has been slightly changed compared to the sensors ERS-1 and ERS-2 (5.300 GHz). To compensate for this frequency change, the interferometric observation geometry needs to fulfill certain requirements, i.e. large baselines or point scatterers. Despite of this fact, surprising results could be achieved on two test sites within relatively short time, demonstrating that cross-interferometry is not just a theoretical possibility but feasible in practice. This fact opens the path for new applications requiring e. g. large baselines.

The first tandem cross-interferogram (Arnault,2003) (figure 2) was generated from two images acquired on the 7th of December 2002 by the ENVISAT ASAR at 10:14:34 (Image Mode, IS2, VV polarization, orbit 4027, Doppler centroid frequency : 236 Hz) and the ERS-2 SAR (Orbit 39899, Doppler centroid frequency : 918 Hz), only 30 minutes later. The perpendicular baseline is of 1650 meters, relatively close to the best theoretical conditions for flat terrain of 2300 meters. It enables a maximum bandwidth overlap between the ERS and ASAR transmitted signals for low incidence angles (see figure 3). Therefore the quality of the interferogram is better at the near range of the image, where there is almost 100% of bandwidth overlap than

for far range where this value is less than 50%. It's interesting to note that urban areas are not coherent in contrast to areas containing distributed scatters. The only coherent parts in the city of Paris are the different parks included in the image. This is explained by the fact that the baseline change compensates only the frequency shift for flat pixels presenting a fully developed speckle. The ones in the city, formed by the reflection on different objects with complicated geometry and important height variation cannot preserve their phase value. Note that total volume decorrelation will appear if scatterers within a resolution cell have height differences of 4 meters [Guarneri et. al. 2000]].

One advantage of using together ERS and ENVISAT is the possibility of making large-baseline interferograms. This technique allows for high vertical accuracy DEM estimation. The large baseline allows for improving the altitude resolution. However, the elevation of ambiguity is very low, making difficult the phase unwrapping task.

REFERENCES

- ArnaudAlain, N. Adam, R. Hanssen, J.Inglada, J. Duro, J. Closa, M. Eineder,; ASAR ERS Interferometric Phase Continuity.
- Bamler R. et. al.: "RADARSAT ScanSAR interferometry". IGARSS '99 Proceedings. Vol. 3 ,pp: 1517 – 1521, 1999.
- Cafforio C., P. Guccione, A. Monti-Guarnieri.: "ASAR Wide Swath Mode: System and Processing Optimization" ENVISAT Calibration Review Proceedings, ESA-ESTEC Sept 2002 ESA-SP-520.
- Davidson, G. W., and Bamler, R.: "Multiresolution Phase Unwrapping for SAR Interferometry ", *IEEE Trans. Geosci. Remote Sensing*, 37, 1999, 163-174
- Fischer, J., R. Bennartz, 1997: ATBD 2.4 Retrieval of Total Water Vapour Content from MERIS measurements, ESA Technical Report PO-TN-MEL-GS-0005
- Eineder M: DEMs in Rugged Terra in Proceedings Igarss 01
- Fornaro, G.; Monti Guarneri, A.M.: "Minimum mean square error space-varying filtering of interferometric SAR data", *IEEE Trans. Geosci. Remote Sensing*, 40, Jan. 2002, 11-21
- Gap, B.-C., A.F.H. Goetz, 1990: Column atmospheric water vapor and vegetation liquid water retrieval from airborne imaging spectrometer data, *J.G.R.*, 95, 3549-3564
- Hanssen, R.F., T.M. Weckwerth, H.A. Zebker and R. Klees: 1999: High-resolution water vapour mapping from interferometric radar measurements. *Science*, 283:1295-12974
- Holzner J., Michael Eineder, and Birgit Schättler: First Analysis of Envisat/Asar Image Mode Products for Interferometry
- Monti Guarneri A. M. and C. Prati. 2000: ERS-ENVISAT combination for interferometry and super-resolution Proc. ERS-Envisat symposium 2000, 16-20 October, Gothenburg, Sweden
- Monti Guarneri, A.M.; Prati,:ScanSAR focusing and interferometry C. *Geoscience and Remote Sensing*, *IEEE Transactions on* , Volume: 34 Issue: 4 , July 1996 Page(s): 1029 -1038
- Monti Guarneri, A., and Rocca, F.: "Combination of Low- and High-Resolution SAR Images for Differential Interferometry", *IEEE Trans. Geosci. Remote Sens.*, 37, 1999, 2035-2049.
- Monti Guarneri; A., C. Cafforio, P. Guccione, P. Pasquali, D. Nüetsch, D. Small, E. Meier & M. Zink, Y. L.: *Desnos Multi-Mode Asar Interferometry: Techniques and Preliminary Results*
- P. Pasquali, et. al.: "Study of the ENVISAT ASAR alternate polarization mode: preliminary results", *Proceedings of EUSAR Symposium, Friedrichshafen, May, 25-27 1998*, pp. 335-338.
- Rosen P. A. et. al. : "SRTM C-band topographic data: quality assessments and calibration activities" IGARSS '01. Proceedings Vol. 2 , 2001 pp: 739 –741
- Torres R., C. Buck, J. Guijarro, J-L. Suchail and A. Schöenberg.: The ENVISAT ASAR Instrument Verification and Characterisation <http://www.estec.esa.nl/ceos99/papers/p099.pdf>,

5. RadarSAT 1

The RADARSAT-1 satellite was launched November 4, 1995 and has been providing imagery for operational monitoring services on a global basis ever since. It is equipped with a state-of-the-art Synthetic Aperture Radar (SAR) that can be steered to collect data over a 1,175 km wide area using 7 beam modes. This provides users with superb flexibility in acquiring images with a range of resolutions, incidence angles, and coverage areas. Basic SAR specifications and some other characteristic data of RadarSAT are listed in Table 5.1 and Table 5.2.

The sun-synchronous orbit also means that the satellite overpasses are always at the same local mean time, which is important to many users. RADARSAT-1 offers users a wide variety of beam selections. The satellite's SAR has the unique ability to shape and steer its beam from an incidence angle of 10 to 60degrees, in swaths of 45 to 500 kilometres in width, with resolutions ranging from 8 to 100 metres. RadarSAT-1 covers the Arctic daily and most of Canada every three days, depending on the swath selected. Data is down linked in real time or stored on the onboard tape recorder until the spacecraft is within range of a receiving station.

Using a single frequency, C-Band, the RADARSAT SAR has the unique ability to shape and steer its radar beam over a 500-kilometre range. Users have access to a wide variety of beam selections that can image swaths from 45 to 500 kilometres in width, with resolutions from 8 to 100 metres and at incidence angles from 10 to 60 degrees.

- RADARSAT provides complete global coverage with the flexibility to support specific requirements. Although the satellite's orbit path is repeated every 24 days, RADARSAT can provide daily coverage of the Arctic, view any part of Canada within three days, and achieve complete coverage at equatorial latitudes every six days using the 500-kilometre wide swath.
- RADARSAT orbits the Earth at an altitude of 798 kilometres with an inclination of 98.6 degrees. The satellite circles the Earth 14 times a day, and each orbit takes 100.7 minutes to complete. The RadarSAT SAR can acquire up to 28 minutes of data per 101 minute orbit. Data is down linked in real time to ground receiving stations or stored on the onboard tape recorder until RADARSAT is within a ground station's range.

RADARSAT was not originally designed for repeat-pass InSAR. Both the orbit accuracy and the repeat cycle of 24 days are not favorable in this respect. On the other hand, RADARSAT's 30 MHz fine-resolution mode combined with large incidence angles gives a critical baseline of as large as 6 km [4]. First results on interferometry using RADARSAT's strip-map modes have been reported in [5][6]. RadarSAT due to its Phase and Frequency stability has SAR Interferometry Capability. DEM's created from RADARSAT and ERS-1 images were compared with a DEM provided by Geomatics Canada Centre for Topographic Information and 1:50 000 topographic maps of the Nahanni region. Comparison of a number of control points from each of the sources showed latitude values that were generally within 0.005° of each other and longitude values that were within 0.01° of each other which amounts to errors of about 500 m. RMS errors were also calculated for flat areas in the RADARSAT and ERS-1 DEM's to see how close they remained to a constant value. The rms errors were around 5 m or less in both the RADARSAT and ERS-1 DEM's when the coherence between the two SAR images was approximately 0.20 or higher. This result shows that it is possible to create DEM's with errors of 5 m rms from interferometric data collected by RADARSAT or ERS-1 if the coherence is high enough.

Both two-pass and three-pass differential interferometry was attempted using ERS-1 and RADARSAT imagery. The two-pass differential interferograms created from ERS-1 and RADARSAT imagery showed potential for detecting surface movements even though the images available were not acquired under conditions favorable for interferometry. The three-pass differential interferogram created using ERS-1 imagery was extremely noisy and did not show the same potential for detecting surface displacement due to extremely low coherence between the ERS-1 images.

RadarSAT SAR Characteristics		Orbit Characteristics		Maximum Coverage Access Periode	
Frequency	5,3 GHz	Altitude	793 km – 821 km	North of 70°N	1 Day
Polarization	HH	Inclination	98,6 °	North of 70°N	4 Days
RF Bandwidth	11,6 13,3, 30 MHz	Period	101 min	North of 80°S	6 Days
Peak Power	5 kW	Ascending Node	18 hrs		
Mean Power	300 W	Sun-synchronous	14 orbits/day		
Max. Data rate					
Antenna Size	15 m x 1,5 m				

Tab. 5.1 RadarSAT SAR Specifications and Orbit characteristics

REFERENCES

Bamler R. et. al.: “RADARSAT ScanSAR interferometry”. IGARSS ,99 Proceedings. Vol. 3 ,pp: 1517 – 1521, 1999

Geudtner D., P. W. Vachon, K. E. Mattar, A. L. Gray, “RADARSAT Repeat-pass SAR Interferometry”, Proc. IGARSS’98, 1635-1637, Seattle, USA, 1998

N.N. http://web.uvic.ca/~jristau/cgu_00.html

Vachon P. W., D. Geudtner, A. L. Gray, R. Touzi.“ERS-1 Synthetic Aperture Radar repeat-pass interferometry studies: Implications for RADARSAT”, Can. J. Rem. Sens. vol. 21, 441-445, 1995

.Vachon, P. W. Geudtner, D., “RADARSAT SAR interferometry” <http://www.ccrs.nrcan.gc.ca/ccrs/tekrd/rd/ana/interfer/interfre.html>

6. Systems under Development

6.1 TerraSAR-X

TerraSAR-X will be a operational German SAR Satellite system for scientific and commercial applications. The program is approved; the system is under development and will be launched in 2006. The goal is to provide the scientific community with multi-mode X-Band SAR data and, additionally, the establishment of a commercial EO-market in Europe by Infoterra. The broad spectrum of scientific application areas include Hydrology, Geology, Climatology, Oceanography, Environmental and Disaster Monitoring as well as Cartography (DEM Generation) with Interferometry and Stereometry.

The scientific potential of TerraSAR-X is based on the unique features of the SAR instrument:

- High geometric and radiometric resolution with an experimental very high resolution 300 MHz mode
- Dual-Polarization mode where two of the possible polarizations (HH & VV, HH &HV or VV & HV) can be acquired simultaneously
- Long term observation with the opportunity for multi-temporal imaging
- Precise attitude and orbit control and determination as well as phase stability e.g. for Repeat-Pass Interferometry
- High synergy potential with other frequency bands (L-Band: ALOS, TerraSAR-L, C-Band: ASAR, RadarSAT)
- New imaging modes like sliding/ starring Spotlight beside ScanSAR and

Center frequency	9.65 GHz	Transmit duty cycle Stripmap	18%
Antenna size (az. x el.)	4.78 m x 0.70 m	Transmit duty cycle Spotlight	20%
Scan angle range (az., el.) ±	0.75°, ± 19.2°	System noise figure	5.0 dB
Incidence angle access range	15° - 60°	Operational PRF range	3kHz – 6,5 kHz
Radiated peak output power	2260 W	Chirp bandwidth range	5 - 300 MHz

Tab.6.1 TerraSAR payload key specifications

- Full operator access to the highly flexible active phased array antenna for the realization of new imaging modes and the acquisition of custom designed image product

The space segment of TerraSAR-X is an advanced high-resolution X-Band radar satellite. An overview on the single polarization basic image product definitions and the expected image performance is given in Tab.6.1. The active phased array front-end is structured in azimuth direction into 3 antenna leafs which comprise of 4 antenna panels each. One antenna panel is built of 32 active sub-arrays in elevation. The phased array is therefore partitioned into 384 phase centres each controlled by one single receiver channel T/R module. A dual polarized waveguide radiator allows the polarization selection via a polarization switch in the T/R module. An overview on the single polarization basic image product definitions and the expected image performance is given in Tab 6.2.

For the orbit selection, an altitude range between 475 km and 525 km has been investigated. The sun synchronous Orbit has an 11 day repeat period. The SAR instrument is capable of operation in three basic

modes: Stripmap-, ScanSAR- and Spotlight-Mode. The possibility of double sided access, enabled by a satellite roll manoeuvre, further improves the operational performance. For spotlight mode, the order-to-acquisition time ranges between 10 and 60 hours and the revisit time is 2.5 days in 95% of the cases.

The Spotlight Mode is based on sliding spotlight operation. Compared to starring spotlight operation, sliding spotlight has the advantage of more uniform NESZ performance achieved in along-track direction due to the averaging of the gain variation of the main beam in azimuth. The performance data for each mode are presented in Table 6.2. The SAR instrument elements are fully redundant, i.e. a main and a redundant

	Spotlight 1	Spotlight 2	Strip Map	ScanSAR
Product coverage				
Along	5 km	5 km	free	free
Across	15 km	15 km	30 km	100 km
Resolution	1 look	1 look	1 look	4 looks
Along	1.0 m	2,0 m	3 m	15 m
Across	1.2 m	1.2 m	3 m	16 m
Incidence Angle	20° - 55°	20° - 55°	20° - 45°	20° - 45°
Full Performance	570 km	570 km	350 km	350 km
Incidence Angle	15° - 60°	15° - 60°	15° - 60°	20° - 60°
Data Collection	622 km	622 km	622 km	577 km
NESC/dB	-19,6....-28,9	-19,7....-29,6	-19,0....-26,5	-18,8....-29,6
DTAR/dB	16,625,4	18,3....27,5	19,0....25,4	19,8....29,6
Tab. 6.2 Performance Specifications of the four Sar Modes of terraSAR				

functional chain exists. It is possible to activate both functional chains at the same time, one being the master for timing purposes. This allows operation in Dual Receive Antenna (DRA) Mode where the echoes from the azimuth antenna halves can be received and then separated during ground processing, e.g. to serve the application of Along Track Interferometry for MTI measurements. In order to enable for tandem operation with a second TerraSAR-X-like satellite, the ultra stable oscillator signal will be broadcasted via a dedicated antenna.

The high precision satellite pointing control and determination is based on a GPS System and star trackers located close to the antenna plane so that an antenna bore sight pointing accuracy of 65 arcsec (3σ) is achieved. Precise orbit determination for geocoding purposes is performed with GPS raw data post processing on ground with an accuracy of <3 m (1σ). A laser reflector is accommodated on the bus to support the orbit determination with laser ranging if required. An additional feature is a Synchronization Antenna for provision of the TerraSAR-X USO signal to potential “slave” satellites in a possible constellation operation (e.g. Cartwheel) using a companion SAR satellite flying in a slightly modified co-orbit of TerraSAR-X. This allows single-pass, across- and along track interferometry with freely selectable, variable baseline distances. Large baselines are required to achieve precision relative height resolution accuracies (<1 m) at flat surfaces, while multiple measurements at different baseline distances are needed for appropriate 3-D mapping of mountainous terrains. Noise Equivalent Sigma Zero (NESZ) and Distributed Target Signal to Ambiguity Ratio (DTAR) both are listed over the full performance range. The “Across Resolution” holds for Slant Range

REFERENCES

Buckreuss S., W. Balzer, P. Mühlbauer, R. Werninghaus, W. Pitz: Terrasar-X, a German Radar Satellite Proc. IRS 2003)

Ebner H., S. Riegger, I. Hajnsek, D. Hounam, G. Krieger, A. Moreira, M. Werner: Single-Pass SAR Interferometry with a Tandem TerraSAR-X Configuration

Mittermayer J., Alberga V., Buckreuss S., Riegger S., ”TerraSAR-X: Predicted Performance”, Proc. SPIE2002, Vol. 4881, Agia Pelagia, Crete, Greece, 22 - 27 September 2002.

Mittermayer J., Lord R., Boerner E., “Sliding Spotlight SAR Processing for TerraSAR-X Using a New Formulation of the Extended Chirp Scaling Algorithm”, proc. IGARSS 2003, Toulouse, 2003, in press.

Mittermayer J., Runge H., “Conceptual Studies for Exploiting the TerraSAR-X Dual Receiving Antenna”,

proc. IGARSS 2003, Toulouse, 2003.

M. Suess, S. Riegger, W. Pitz, R. Werninghaus, "TerraSAR-X – Design and Performance", Proc. Of EUSAR2002, Köln, Germany.

6.2 RadarSAT-2

RADARSAT-2, presently planned for a late 2004 launch, is as a successor of RadarSAT-1 an advanced SAR satellite. RADARSAT-2 has polarimetric capability and like RadarSAT -1 interferometric capability also. RADARSAT-2 offers three polarimetric modes: (1) selective polarization (dual pol) providing one co-pol channel (HH or VV) and the corresponding cross-pol channel (HV); (2) high resolution (3 m) single pol channel (HH or VV); and (3) a fully polarimetric mode (quad pol) providing both amplitude and phase. The fully polarimetric mode is significant since RADARSAT-2 is the first commercial satellite to offer this mode. The commercial focus of the RADARSAT-2 mission dictates the development of operational applications, and ultimately the extraction of information from the SAR data. RADARSAT-2 retains the same capability as RADARSAT-1 (Luscombe, 2001), but has advanced SAR-based Earth Observation (EO) by offering enhanced features including: 3 m high resolution mode Selective and Polarimetry modes, enhanced ground system providing rapid satellite tasking and near-real time data processing, routine left and right looking capability, increased geometric accuracy leading to improved image location accuracy, and on board solid state recorders. The RadarSAT-2 modes are listed with respect to names and performance in Tab 6. 3.

References used in 6.2

Staples G:C., J.Hornsby: Turning the Scientifically Possible into the Operationally Practical: Radarsat-2 Polarimetry Applications presented at International Remote Sensing of Environment, Buenos Aires, Argentina, April 2002.

	Beam Mode	Nominal Swath	Swath Coverage to Left or Right of Ground Track	Resolution Rge x Az
Selective Polarization: Transmit H or V Receive (H or V) or (H and V)	Standard	100 km	250km - 750km	25 m x 28 m
	Wide	150 km	250km – 650km	25 m x 28 m
	Fine	50 km	525km – 750km	10 m x 9 m
	ScanSAR Wide	500 km	250km – 750km	100m x 100m
	ScanSAR Narrow	300 km	300km – 720km	50m x 50m
Single Polarization HH	Low Incidence	170 km	125km – 300km	40m x 28m
	High Incidence	70 km	750km – 1000km	20m x 28m
Full Polarization Transmit H and V with alternate Pulses, Receive H and V on every Pulse	Standard QP	25 km	250km – 600km	25m x 28m
	Fine QP	25 km	400km – 600km	11m x 9m
Selective Single Pol Transmit H or V Receive H or V	Multiple Fine	50 km	400km- 750km	11m x 9 m
	Ultra- fine Wide	20 km	400km- 550km	3 m x 3 m

Tab.6.3 RadarSAT-2 Modes and Performance

6.3 ALOS/PALSAR

ALOS stands for Advanced Land Observing Satellite, it is an Japanese Earth Observation Satellite and houses the Phased Array type L-band Synthetic Aperture Radar (PALSAR), centre frequency is 1,270 GHz. as a successor of the JERS-1 SAR beside the Panchromatic Remote-sensing Instrument for Stereo Mapping (PRISM) for digital elevation mapping, the Advanced Visible and Near Infrared Radiometer type 2 (AVNIR-2) for precise land coverage observation . The fine resolution SAR mode is a conventional one. The PALSAR will have a ScanSAR mode, which will allow to acquire a 250 to 350 km width (depending on number of scans). The Launch is expected for late 2004.

REFERENCE: <http://www.eorc.jaxa.jp/ALOS/about/2palsar.h>

	High Resolution Mode		ScanSAR	Experimental Polarimetric
Chirp Bandwidth	28 MHz	14MHz	14MHz, 28MHz	14MHz
Polarization	HH or VV	HH+HV or VV+VH	HH or VV	HH, VV, HV, VH
Incident angle	8 ~ 60 deg	8 ~ 60 deg	18 ~ 43 deg	8 ~ 30 deg.
Range Resolution	7 ~ 44m	14 ~ 88m	100m (multi look)	24 ~ 89m
Observation Swath	40 ~ 70 km	40 ~ 70 km	250 ~ 350km	20 ~ 65km
Data rate	240Mbps	240Mbps	120Mbps, 240Mbps	240Mbps
NE Sigma zero	< -23dB (Swath Width 70km) < -25dB (Swath Width 60km)		< -25dB	< -29 dB
Signal/Ambiguity	> 16dB (Swath Width 70km) > 21dB (Swath Width 60km)		>21 dB	> 19 dB
Radiometric Accuracy	scene :1dB / orbit :1.5 dB			

Tab.6.4 Basic ALOS/PALSAR Specifications

6.4 SAR-Lupe

SAR-Lupe is a satellite system for global surveillance; goal is the generation of SAR- pictures with high resolution for military reconnaissance purposes.

The main system features, being optimised with respect to the requirements, to enable a world wide continuous reconnaissance of large scenes delivering high quality actual data with respect to highest resolution and image quality by X-Band SAR with a global coverage from 80°N to 80°S.

The SAR-Lupe system consists of 5 identical satellites in 3 polar orbit planes at approx. 500 km altitude. They use the same antenna for image acquisition and X-band data downlink, and are equipped with an S-Band link for commanded telemetry via ground station and via inter-satellite link. The main characteristics of the SAR-Lupe satellites are:

- ◆ Size approx. 4m x 3m x 2m
- ◆ Mass ca. 770kg
- ◆ Average power ca. 250W
- ◆ Life time 10 years
- ◆ Reliability ~ 98% per year
- ◆ Orbit control: Hydrazin system
- ◆ On board memory > 128 GB
- ◆ Images per day > 30
- ◆ Spatial resolution < 1 m

The system will have a strip map and a spotlight mode, the latter will be steered by reduction of ground velocity (~ 7 km/sec) obtained by turning the satellites attitude mechanically which leads to

- ◆ Highest Resolution within 5,5km x 5,5 km
- ◆ High Resolution within 8 km x 60 km (total test area)
- ◆ System Response Time <11 hours mean, <19 hours 95%, more than 30 images /day in total area of interest.

The system is based on today available technology. To secure and guarantee operation for more then 10 years high redundancy concepts are employed. The first satellite is planned to be launched with a Russian launcher in 2006, the whole system shall be in orbit by 2008.

References for 6.4

www.ohb-system.de/Security/sarlupe.html

Penné1 B., C. Tobehn1, M. Kassebom1, H. Lübberstedt1 The Earth Observation Program at OHB-System, <http://www.iaonet.org/symp/berlin/IAA-B4-0201.pdf>

7. Airborne Systems

There exists worldwide a very large fleet of airborne SAR-Systems 25 (Kramer, 2000)Examples for airborne SAR with principal Polarimetric and interferometric capability are E-SAR (DLR), Do-SAR (EADS), Ramses (ONERA), AES (FGAN), SAR-580 (CCRS). Table 7.1 lists some specifications.

Instrument (Agency), Country	Frequencyx (Baud /GHz)	Polarization
C/X-SAR – CCRS,Canada	5.3/© 9.25/(X)	C. full polarimetric, X: V or H
DO-SAR (EADS), Germany)	3.2/(S) 5.3/© 9.6/(X) 35/(Ka)	full polarimetric
EMISAR - EMI/ TUD Denmark	5.3/© 1.4/(L)	Full polarimetric
E-SAR (DLR), Germany	0.450/(P),1.3/(L) 5.3/© 9.6/(X)	P + L: full polarimetric C: VV or HH X: V or H
AER (FGAN), Germany	X	full polarimetric one pass Interferometry
MMW-SAR - MIT	33.56/(Ka)	V, H, full polarimetric
NASAR (NASDA/ EORC), Japan	1.291 (L-Band)	full polarimetric
P-3/SAR - ERIM, Navy, US	0.350/(UWB) 1.25/(L) 5.30/© 9.35/(X)	full polarimetric
PHARUS - TNO-FEL Delft, The Netherlands	5.25/©	full polarimetric
PI-SAR (CRL, NASDA), Japan	9.55 (X), 1.27 (L)	X: full polarimetric
RAMSES (ONERA), France	1.6/(L),3.0/(S), 6.2/©, 9.5/(X), 14.5/(Ku) 35/(Ka) 95/(W)	full polarimetric

Tab.7.1 Overview of some early airborne SAR systems (Kramer, 2000)

Presently, UAV’s gain increasing attention. They normally operate in a variety of weather conditions, from conventional airport, and above 12,000 meters to avoid commercial traffic and reduce turbulence. This reduces the requirements for motion compensation. They are able to maintain a flight path with positional accuracy of ±5 meters, have a minimum range capacity of 2000 nautical miles, a payload capacity of 300 kilograms with a volume of 1 cubic meter. They have 2,000 watts of DC power available for the payload as a minimum, support over-the-horizon up- and downlinks for communication and data transmission.. They are able to mount an external, side-looking, active array antenna (0.5m by 2.0m) without obstruction. Examples are Global Hawk , US

The interferometric accuracy obtained with airborne Interferometric SAR is dependent strongly on the exact knowledge of all flight pass and attitude parameter of the platform used also. In Fig. 7.1 the influence of motion errors on a DEM is depicted. However, the estimation of extremely high accuracies requires extremely exact calibration and extremely accurate reference sources

Single pass and two pass interferometry as well with airborne SAR has an accuracy of 0,1 m up to 1 m. With differential interferometry accuracies in the cm range have been obtained. The vertical accuracy which can be obtained is dependent on terrain height variations, pixel posting, horizontal resolution, distance R, and incidence angle. However, the estimation of extremely high accuracies requires extremely exact calibration and extremely accurate reference sources.

The Table 7.2 points out the influences of the SAR geometry on the obtainable accuracy, Table 7.3 shows the terrain type influence. Table 7.4 compares results obtained in Solothurn, Switzerland, over a relatively flat area.

Posting	Absolute accuracy		Relative accuracy		
	Horizontal	Vertical	Horizontal Near Range	Horizontal Far Range	Vertical Near vs. Far Range
10 m	10 m	10 m	3 m R < 200m	10 m R > 200 m	1 m – 3 m
3 m	10 m	5 m	2 m R < 100 m	10 R > 100 m	0.5 m – 1 m
1m	5 m	5 m	1 m R < 50m	5 m R > 50 m	0.15 m – 0.5 m

Table 7.2. Accuracies obtained with airborne one pass interferometry

	Absolute Mean Height Deviation	Standard Deviation	Minimum Height Deviation	Maximum Height Deviation
Digital Camera	0.77 m	0.97 m	- 2.20 m	1.38 m
AES – SAR (X-Band)	0.14 m	0.17 m	- 0.54 m	0.21 m
Laser Scanner	0.40 m	0.43 m	- 0.87 m	0.77 m
DHM25 (official DEM)	1.28 m	1.66 m	- 3.25 m	5.49 m

Reference Values Obtained from Measurements with 24 Trigonometric Reference Points

Tab. 7.3 Height Accuracies Obtained with Different Sensors Measured Height Deviations from Measured Reference [J.Moreira, MFFU + RSL, Zürich]

Applications include detection and identification of targets, target false alarm reduction, large scale topographic mapping, rapid assessment of topographic changes on battlefields and monitoring long term changes such as building facilities, erosion, roads, ways, and passes, secondary minefield effects

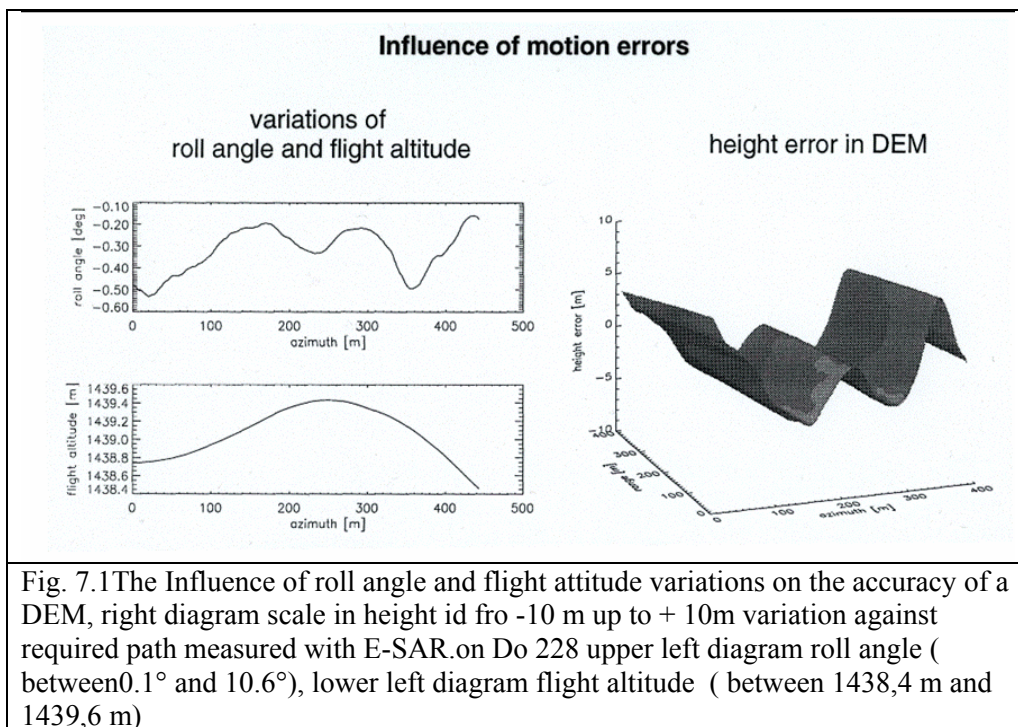

Fig. 7.1 The Influence of roll angle and flight attitude variations on the accuracy of a DEM, right diagram scale in height id fro -10 m up to + 10m variation against required path measured with E-SAR.on Do 228 upper left diagram roll angle (between 0.1° and 10.6°), lower left diagram flight altitude (between 1438,4 m and 1439,6 m)

Area	Type of Coverage	Type of Topography	Validated Accuracy	Validation Reference Source
Bremerhafen Germany	Tidal Flats	Flat, Height Variations \leq 1m	5 cm	Theodolite Measurements
Solothurn Switzerland	Meadows Open Fields	Flat, Height Variations \leq 150m	17 cm	24 Triogonometric Points
Juazeirodo Norte Brazil	Sparse Vegetation	Hilly, Height Variations \leq 500m	25 cm	D-GPS Measurements
Maastricht The Netherlands	Meadows Open Fields	Flat, Height Variations \leq 100m	22 cm	Laser Scanning DEM

Tab. 7.4 X-Band: Height Accuracy obtained from Different Terrain Types [J.Moreira, MFFU]

8. Future Systems

Future SAR systems, in general, will be software based multi static systems characterized by multi-polarization and multi-frequency capability, and multiple operation modes as well. They will have individual transmit and receive antennas which are mounted on separate platforms, one or more central illuminators together with a synchronized fleet of airborne, space borne, or ground based receivers which enable continuous availability with a nearly global coverage. Such a spatial separation has several operational advantages which will increase the capability, reliability and flexibility of future SAR missions. The transmitter and receiver satellites may be in low earth orbit (LEO), medium earth orbit (MEO), or geosynchronous orbit (GEO) and the whole satellite constellation can be optimized for different applications which require frequent monitoring and/or wide swath imaging.

Such systems can be optimized for a broad range of applications like frequent monitoring, wide swath imaging, single-pass cross-track interferometry, along-track interferometry, resolution enhancement or radar tomography. Further potential arises from digital beam-forming on receive, which allows to gather additional information about the direction of the scattered radar echoes. That directional information can be used to suppress interferences, to improve geometric and radiometric resolution, or to increase the unambiguous swath width. Furthermore, a coherent combination of multiple receiver signals will allow for a suppression of azimuth ambiguities. Examples are single-pass cross track interferometry for the generation of highly accurate digital elevation models (DEMs), sparse aperture constellations for moving target indication and large area traffic monitoring, along-track interferometry for the mapping of ocean currents and ice drift, bistatic scattering for improved scene classification, and polarimetric interferometry or even tomography for 3-D vegetation mapping.

Precision formation flying technology will allow deployment of a large number of low cost, miniaturized spacecraft and introduction of new members to the formation over time. The formation flying system must act collaboratively as a single collective unit. The guidance and control system for formation flying must be on board with autonomous formation position determination capability, autonomous navigation, formation estimation, and path planning functions capability. Extreme pointing and attitude stability is required. Especially the control of spacecrafts in low orbits poses significant challenges due to several non-uniform perturbations that can potentially destabilize the formation geometry and decrease the measurement accuracy of the system. The Cartwheel concept [Massonet, 1999; Krieger 2003] a parasitic SAR system with 3 small satellites (300 kg or less) rotating on the same orbit around each other with permanent interferometry capability is an example for present possibilities and considerations Fig. 8.1. In Fig. 8.2 a visionary system is depicted

REFERENCES

This section is mainly based on Keydel W.; Perspectives and Visions for future SAR Systems, IEE Proc.-Radar Sonar Navig. Vol. 150 No. 3 June 2003. with further references.

D KRIEGER, G., FIEDLER, H., MITTERMAYER, J., PAPATHANASSIOU, K., and MOREIRA, A.: 'Analysis of multi-static configurations for space-borne SAR interferometry', *IEE Proc., Radar Sonar Navig.*, 2003, 150, pp. 87-96

MASSONNET, D.: 'Capabilities and limitations of the interferometric cartwheel'. Proceedings of CEOS Workshop, October 1999, Manuscript available at <http://www.estec.esa.nl/confannoun/99b02/index.html>

Multistatic SAR Interferometry: „Cartwheel“

3 Passive Receiver Satellite:

On Master Orbit Master with equal Eccentricity, 120° shifted Along- & Across-Track- Baselines Stable maximal vertical Baseline

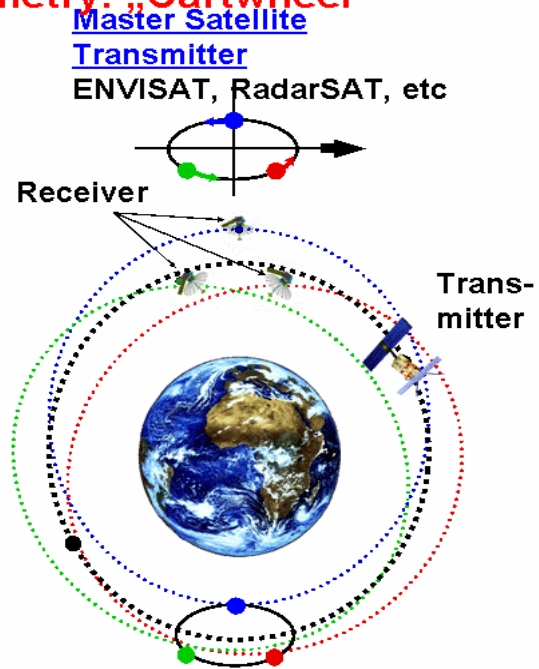
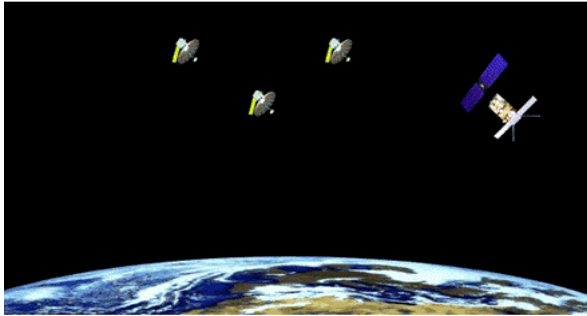

Fig. 8.1 Model of the Multistatic Cartwheel system

Fig. 8.1 Model of the Multistatic Cartwheel system with one Master Satellite and three Parasitic satellites

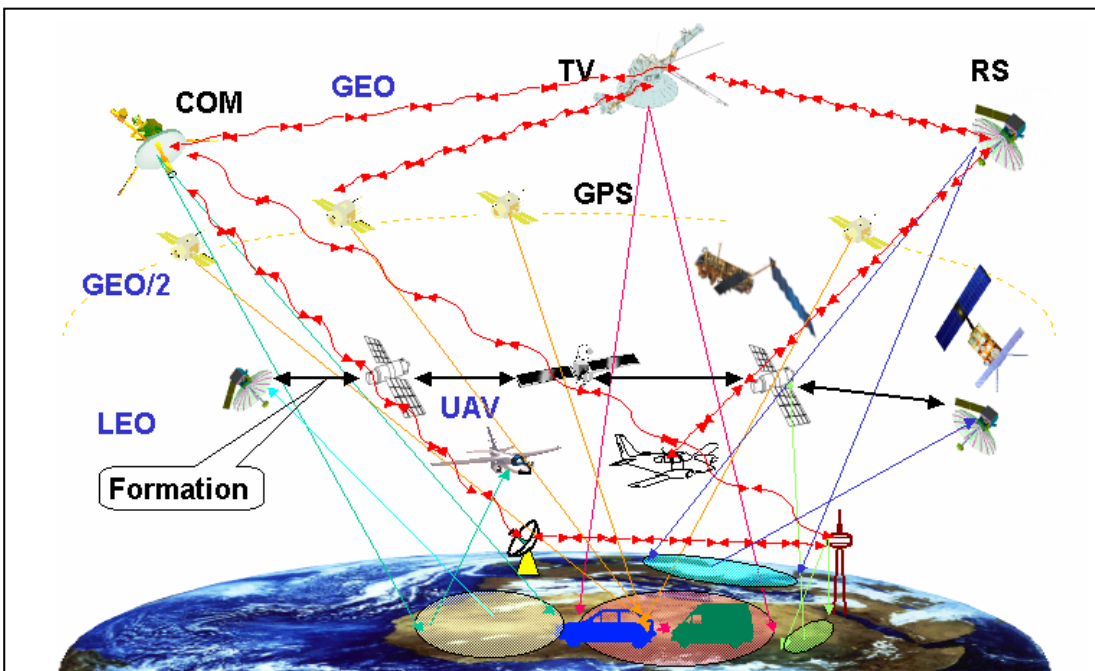

Fig.8.2 Scheme of a global Remote Sensing System wit COMNAV capacity based on multistatic application of different sensors to be used as transmitters and receivers as well.

